

WATER WITCH®

PATENT
PENDING



Float Switch Replacement

Model 101 101-24

- *MERCURY FREE*
- *OILS AND FUELS — Will not activate switch*
- *SIMPLE INSTALLATION — Mounts at any angle*
- *DELAY ON — To avoid false pump cycles*
- *DELAY OFF — Controls standing water level*
- *ELECTRONIC — No wear, sticking, or electrolysis*
- *STAINLESS STEEL METAL PARTS*
- *EXCEEDS BOTH U.S. COAST GUARD & U.L. STANDARDS*
- *20 YEARS — Marine experience*

5 YEAR
LIMITED
WARRANTY

MEMBER
ABYC®
Setting Standards for Safer Boating

SPECIFICATIONS:

Power Required: 12 Vdc (Model 101)
24 Vdc (Model 101-24)

Power used: .004 Amps.

Size: 2.135" W x 1.350" H x 1"D

Weight: 3 Ounces

Delay on: 6-8 Seconds

Delay off: 14-16 Seconds

Max load: 15 Amps. (Model 101)
10 Amps. (Model 101-24)

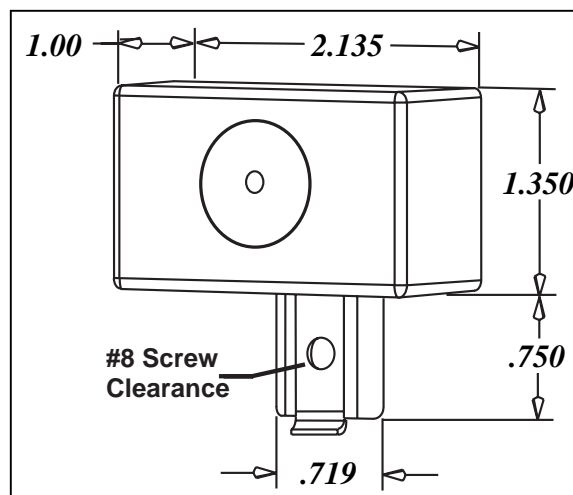

TOP
MOUNT

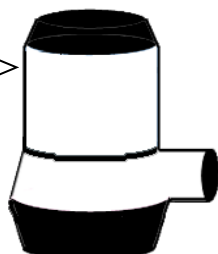

HOSE
MOUNT



See instructions on reverse →

Replacing your old float switch

Confirm float being replaced is on the positive (+) side of the pump.

1. Cut and splice the RED wire on the model 101 to the (+) wire coming from the battery .
2. Cut and splice the BROWN wire from the model 101 to the positive pump wire.
3. Cut and splice the BLACK wire on the model 101 to common ground (-).

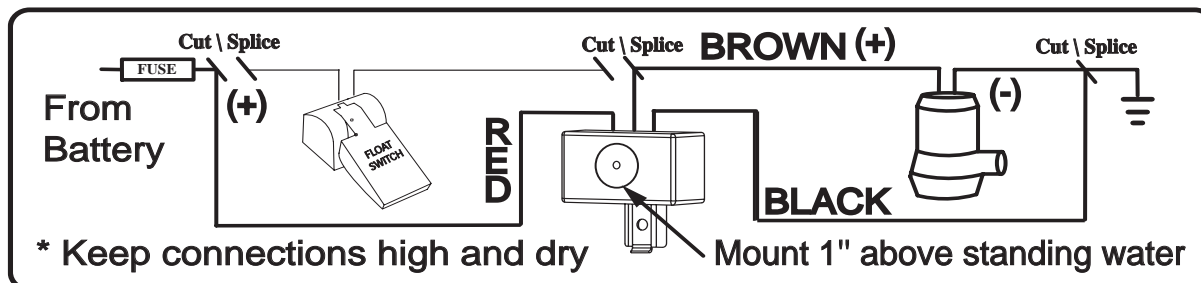

CAUTION:

- Connecting the BROWN wire to ground, as this may damage the switch.
- Mount the Model 101 with sensor about 1" above standing water in your bilge.
- Make all wire connections sealed and above any water contact.

TESTING:

Test the Water Witch by placing a wet rag across the sensor and the metal mounting bracket for the 8 second delay period required to turn on the pump.

Every time power is applied, the Water Witch will operate the pump for several seconds in a self calibrate mode.

Common Wiring Configurations

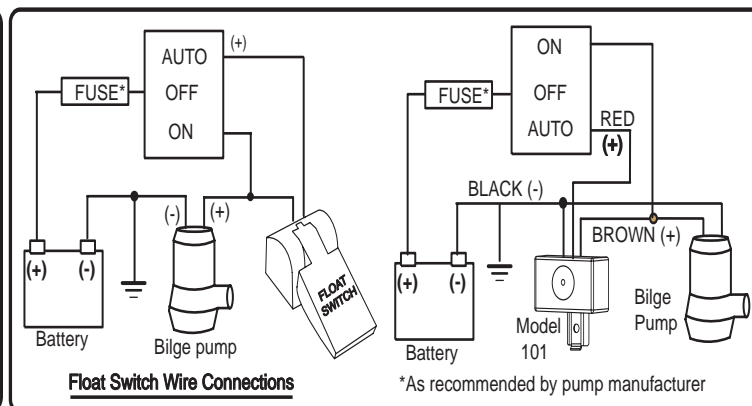
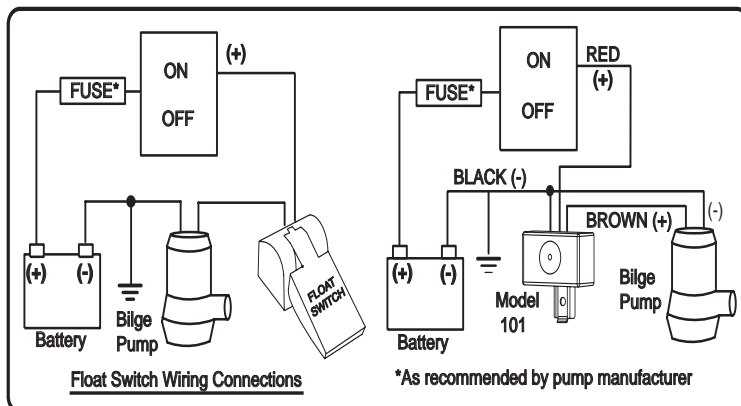

2-way switch

3-way switch

NOTE:

If large amounts of rain water can enter the bilge, it may dilute the normal, fresh or salt, water outside our sensitivity window. Corrective action can be to switch pump on manually to remove diluted water or to add minerals such as salt, baking soda, bilge cleaners, etc... **NORMAL FRESH WATER HAS AMPLE MINERAL CONTENT FOR PROPER OPERATION.**

LIMITED WARRANTY

WATER WITCH, INC. warrants this *control* for a period of 5 years from the date of purchase against defects in material and workmanship providing it has not been subject to physical or electrical abuse or misuse. If it ceases to operate, return *control*, freight prepaid, with a copy of your sales receipt. Water Witch, Inc. reserves the right to repair or replace the *control* at its option. **IN NO EVENT WILL WATER WITCH, INC. BE LIABLE FOR MORE THAN THE REPLACEMENT COST OF THE CONTROL UNDER THIS WRITTEN WARRANTY OR UNDER ANY IMPLIED WARRANTY OR MERCHANTABILITY.** This warranty gives you specific legal rights. However, you may also have other rights which vary from state to state and country to country.